

Nippon-Denso

Toyota, Carbureted
L Terminal to Drive Choke
IN223 Reg.

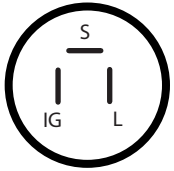

FROM ORIGINAL
ALTERNATOR HARNESS

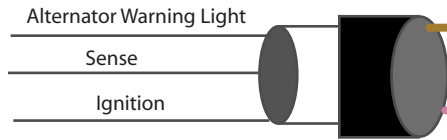

NOTE: Not all wires from the 10-pin harness will be used.

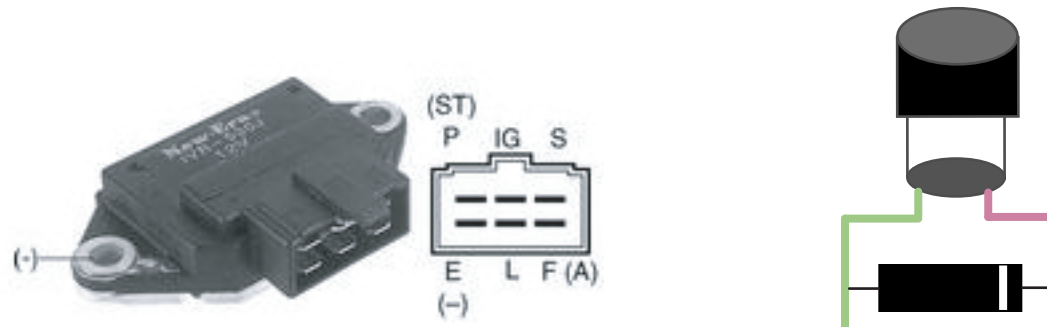
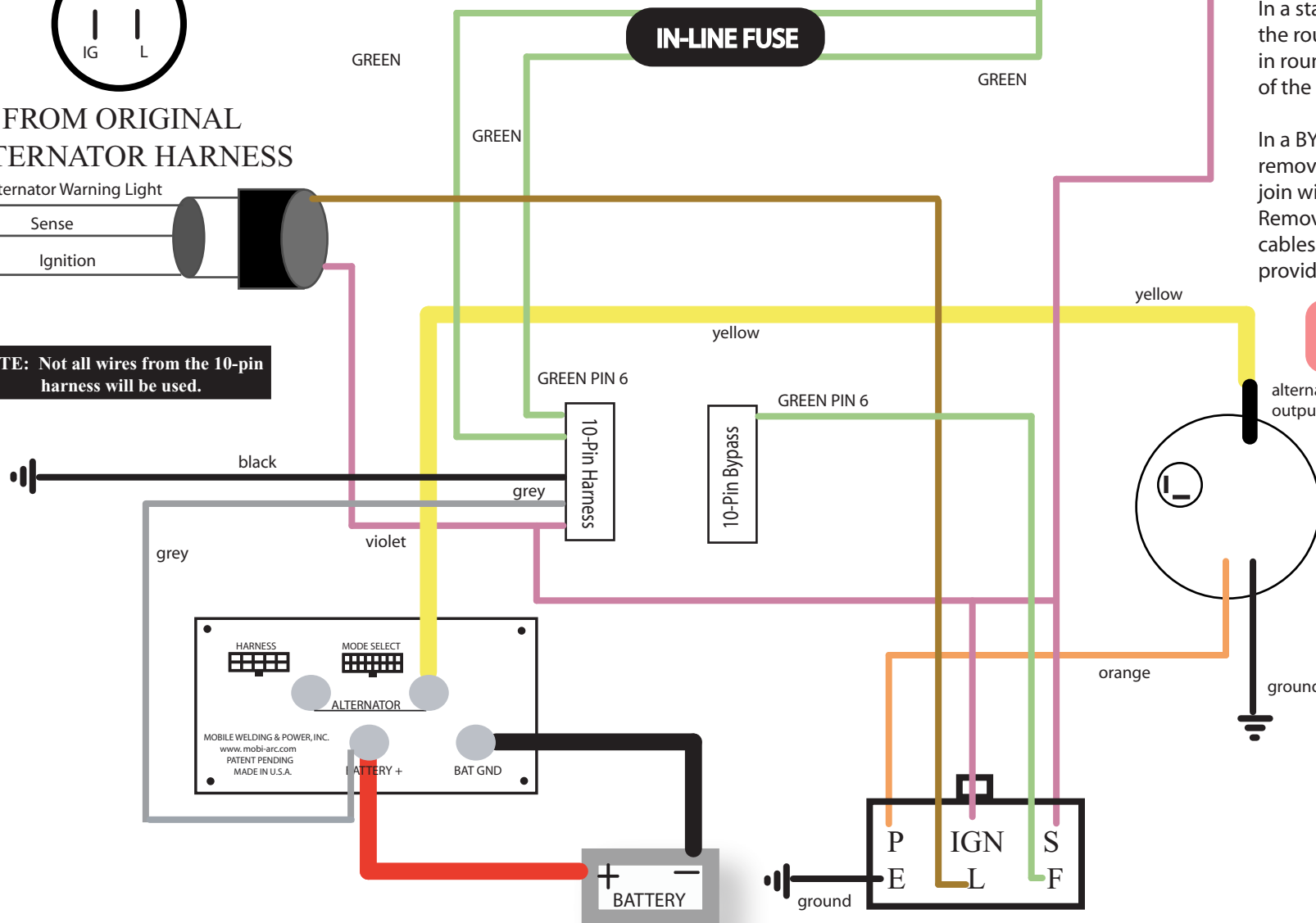

DIAGRAM #7020



NOTE STRIPE ON DIODE

In a standard configuration, the round plug will be inserted in round receptacle on the back of the alternator.

In a BYPASS configuration, remove 10-pin harness plug and join with 10-pin BYPASS plug. Remove #4 red & yellow cables and join together on bolt provided in BYPASS Kit.

ORIGINAL ALTERNATOR OUTPUT CABLE NOT USED

