



Repair Harness

NOTE: When the original alternator harness does not mate to the alternator, a repair harness has been provided. The "L" terminal needs to be connected to switched 12 volts through a light, no other connections on the repair harness are required. In some cases, a 10-Pin mated BYPASS Plug, when mated to the 10-pinwire harness will provide switched 12 volts automatically when the Bypass configuration is present.

ORIGINAL ALTERNATOR OUTPUT CABLE NOT USED

NOTE: Not all wires from the 10-pin harness will be used.

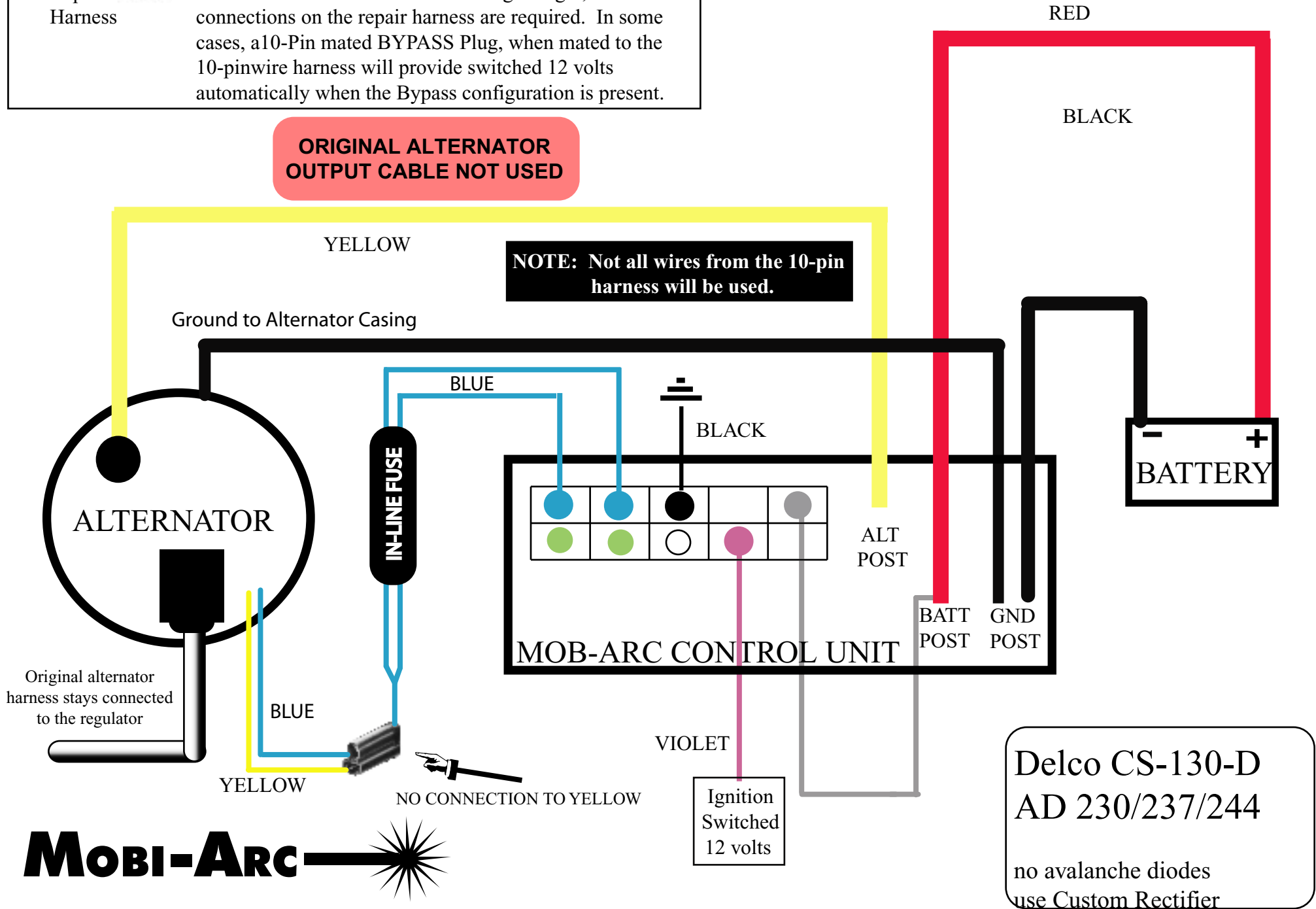

Delco CS-130-D
AD 230/237/244
no avalanche diodes
use Custom Rectifier