

POWER-GATE INSTALLATION INSTRUCTIONS

SR-Series Battery Isolator

Congratulations on your **POWER-GATE** purchase! **POWER-GATE** is designed to provide years of trouble-free operation. Please read the instructions in their entirety prior to undertaking installation. Like any work performed around batteries, electrical circuits, vehicles, and moving parts, exercise caution to insure safe installation and use of your multi-battery accessory. If you are not familiar with batteries, electrical circuits, or basic auto/marine-electrical architecture, seek the assistance of a professional installer. Failure to install **POWER-GATE** correctly may cause poor performance, premature product failure, personal injury, or possibly damage to the vehicle or vehicle accessories.

The manufacturer is not responsible for damage incurred due to improper installation.



PRE-INSTALLATION

PACKING LIST:

- POWER-GATE Module (1)
- Vinyl blade insulators (2)
- Nylon insert nuts, 5/16-20 (2)
- Brass washers, 5/16 (2)
- Ground lead with in-line fuse (1)

WHAT YOU WILL NEED:

- In-line fuses (2) scaled to alternator output
- Copper lugs for cable terminations
- Digital multi-meter
- 5/16 inch nut driver
- 20 AWG black wire for ground extension
- Wire stripper
- Lug crimper
- Soldering torch, solder, and flux

INSTALLATION INSTRUCTIONS

Step 1 With engine off, remove all wires and cables from negative terminal of all batteries.

Step 2 Select desired location for POWER-GATE Module; keep the following points in mind:

- Distance to the alternator and batteries
- Easy access to POWER-GATE
- Footprint doesn't conflict with other wires, cables, reservoirs, rotating parts etc...
- Adequate distance from high-heat sources like exhaust manifold

Step 3 Mount POWER-GATE with provided #6 x 1/2 self-tapping screws.

Step 4 Connect POWER-GATE fused ground wire to good electrical ground (ex. Either battery negative terminal) **before proceeding to Step 5.**

Step 5 Connect cables to POWER-GATE anode as shown in diagram. **FUSE** and insulate appropriately. Torque nylon insert nut to 75 inch-pounds +5/-0 (8.5 newton-meters)

Step 6 Connect cable(s) to POWER-GATE cathode as shown in diagram and insulate appropriately. Torque nylon insert nut to 75 inch-pounds +5/-0 (8.5 newton-meters)

Step 7 **BEFORE RECONNECTING BATTERIES**, verify that your installation matches the SR-Series diagram.

Step 8 While watching GREEN led(s) on POWER-GATE, momentarily tap the disconnected ground cable to the negative post on anode-connected battery (auxiliary battery in diagram). The GREEN led(s) should instantly illuminate if aux. battery is of equal or higher voltage than the cathode battery. If not, **STOP**, check your work, and call for technical support.

Step 9 Restore ground connections on both batteries and proceed to Post Installation Checkout.

SR-Series, Multi-Battery Diagram
Negative Ground Electrical System

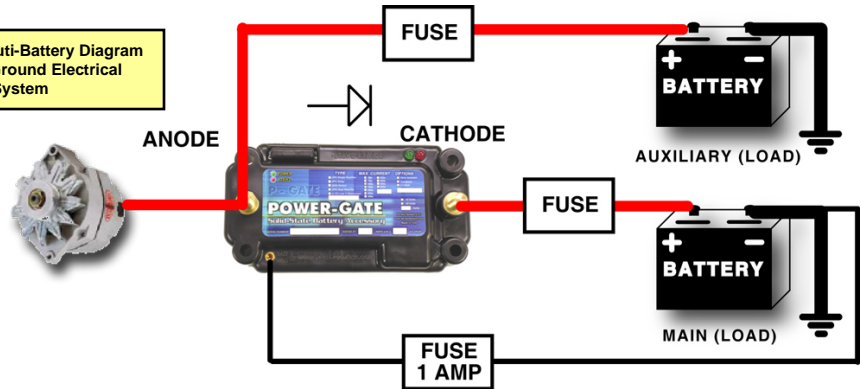

POST INSTALLATION CHECKOUT

Assumptions:

- Both AUXILIARY and MAIN batteries have a normal static voltage of 12 to 13 volts. AUXILIARY battery reads the *same voltage or higher* than MAIN battery.
- Cables and connections are pristine and electrically sound, not poor, corroded, or high resistance.

Using your digital multimeter, perform the following checks:

1. Read the DC voltage from the anode to ground. This should reflect the DC voltage of the AUXILIARY battery.
2. Read the DC voltage from the cathode to ground. This should reflect the DC voltage of the MAIN battery
3. With one probe on anode and one probe on cathode, the multimeter will reflect the difference between these two points and should reflect less than 0.05 volts. If greater, disconnect batteries, as this indicates excessive current being transferred from the AUXILIARY battery to the MAIN battery. There should never be more than 0.05 volts drop between the anode and cathode blades at **maximum rated current**.

HOW POWER-GATE™ FUNCTIONS

The POWER-GATE™ Module is an extremely efficient, one-way electrical valve. It provides electrical conduction from anode to cathode more efficiently than the cables attached to it. In normal operation, the alternator is supplying current to both the MAIN and AUXILIARY batteries. POWER-GATE™ will prevent the MAIN battery from being depleted by the AUXILIARY battery and its connected loads by blocking reverse current flow.

POWER-GATE™ is always on; there's no on/off switch. It continuously draws 0.002 to 0.025 amps from the AUXILIARY battery (which is less than the power consumption of your vehicle's clock) in the process of protecting your MAIN battery.

The **GREEN** LED indicates proper operation.

If the **GREEN** LED is not illuminated, it means the following:

- the voltage at the anode is less than the voltage at the cathode indicating the MAIN battery is being protected
- Under-voltage (less than 8 volts)

The **RED** LED will illuminate in the case of over-current.

POWER-GATE™ is encapsulated to provide rigidity, and protection from chemicals, dirt, and moisture. It is non-serviceable and non-repairable.

See reverse side for more information.....



CONNECTING CABLES TO POWER-GATE™

POWER-GATE™ lacks cooling fins commonly present on multi-battery isolation devices. It is critical that cable connections to anode and cathode provide optimum surface area contact for proper electrical conductivity.

IN-LINE GROUND WIRE FUSE

The external ground wire must be grounded to the battery negative terminal before connecting cables to either the anode or cathode. Failure to do so may cause the POWER-GATE™ to heat up and fail.

A fast-blow 1amp fuse has been fitted in the weather resistance fuse-holder. Should a battery get connected in reverse-polarity, the one amp fuse will blow in order to protect the POWER-GATE™ from reverse-polarity damage. Should the one am fuse blow, it's imperative to replace it before re-connecting the battery in the correct polarity. Failure to do so may cause the POWER-GATE™ to heat up and fail.

CONNECTING LUGS TO CABLES

POWER-GATE™ is engineered to transfer electricity at peak performance levels approaching 99.9%. Unfortunately, most installers often overlook electrical joints between cables, lugs, and battery terminals. POWER-GATE™ is one part of a complete electrical *system*; cables and connection points require just as much attention as the connections to POWER-GATE™ itself.

- Cables should be flexible, free of oxidation, and coated with neoprene or some sort of insulation
- Cable cross-section should be appropriately sized for the distance and peak current being transferred.
- Lugs made of copper or silver-plated copper are good conductors.

Creating a good joint between cables and connectors insures efficient transfer of electricity. Lugs should be soldered to cables; hand crimping *does not* provide enough compression for a good joint. To properly connect cable to lug:

1. Strip cable's insulation material exposing copper strands of cable.
2. "Tin" copper strands by first covering with solder flux. Heat copper strands with torch until solder melts into copper strands. The goal is to pre-saturate the copper strands with solder.
3. Insert solder slugs into lug barrel followed by tinned cable.
4. Use torch to heat lug and cable. When the solder slugs melt, molten solder from tinned cable and solder slugs will combine while inserting cable into lug.
5. Remove heat and allow lug and cable to cool.
6. Once cool, use heat shrink wrap or electrical tape to create moisture barrier between cable insulation and lug.

This method should produce a sound electrical joint. Later, use a digital multimeter to insure connection is less than .01 volts at 100 amps.

DEVICE FAILURE



Should POWER-GATE cease to function correctly for any reason, it is important to remove the device from the electrical circuit. Like any component in an electrical distribution circuit, if it is not functioning correctly, the POWER-GATE will dissipate heat as current passes through it. If ignored, heat related damage could result if a faulty device is not removed. Perfect Switch, LLC cannot be responsible in any way for ancillary damage to the vehicle and equipment installed in, on, or about the vehicle. Electronic components can cease to function at any time. It is the operator's responsibility to frequently assess the health of the electrical system to insure a safe and reliable working environment.

AWG Size American Wire Gauge	Resistance in Milliohms per foot	Voltage Drop Per Foot	
		at 100 amps	at 250 amps
00	.078	.0078V	.0195V
0	.098	.0098V	.0245V
1	.124	.0124V	.031V
2	.156	.0156V	.039V
3	.197	.0197V	.0495V
4	.249	.025V	.0625V
6	.395	.039V	.0975V
10	.999	.1V	.250V

THIS SPACE FOR NOTES

POWER-GATE ONE-YEAR LIMITED WARRANTY

Perfect Switch, LLC. warrants the POWER-GATE against all defects in materials and workmanship for a period of one year from the date of the original purchase, subject to the following terms and conditions:
This warranty does not apply if the serial number or housing of the product has been removed or if the product has been subjected to physical abuse, improper installation, water damage, corrosion due to sea salt, road salts, or de-icing chemicals, transient voltage spikes, or modification.

To obtain warranty service, please contact the manufacturer for a Return Materials Authorization (RMA) number. The product must be returned, insured and shipping prepaid, to Perfect Switch, LLC at the address below, in its original packaging or a suitable equivalent, along with the purchaser's receipt and written description of the problem.

Perfect Switch, LLC's responsibility under this warranty is limited to repair or replacement of the product or refund of its purchase price, at the sole discretion of Perfect Switch, LLC. Perfect Switch, LLC. disclaims all other warranties, expressed or implied, including warranties of merchantability and fitness for any particular purposes whatsoever, and no other remedy shall be available including without limitation, incidental or consequential damages, loss of time, inconvenience, or commercial loss. In no event shall Perfect Switch, LLC's liability exceed the purchase price of the product in question.

Some states do not allow the exclusion or limitation of incidental or consequential damages of how long an implied warranty lasts, so the above limitations or exclusions may not apply to you.

This warranty gives you specific rights. You may have other legal rights which may vary from state to state. Perfect Switch, LLC. wants you to be satisfied with its products. Should you have any difficulties with the operation or performance of your POWER-GATE multi-battery accessory, please the manufacturer.

Perfect Switch, LLC
11722 Sorrento Valley Road
Suite E
San Diego, CA 92121 USA

(858) 720-1339 Phone
(858) 720-8556 Fax
www.perfectswitch.com
info@perfectswitch.com



© Perfect Switch LLC. All Rights Reserved. 2009

US and Foreign Patents Pending